

C700 Positive Displacement Meter

Waterworks or Low-Lead Bronze, Magnetic Drive, External Threaded Spuds

Size: 5/8" x 1/2" & 5/8" x 3/4"



Performance:	Size: 5/8" x 1/2"	5/8" x 3/4"
95%-101% Accuracy GPM	1/8	1/8
97%- 101% Accuracy GPM	1/4	1/4
98.5% -101.5% Accuracy GPM	1-20	1-20
Continuous Flow GPM	15	15
Maximum Flow GPM	20	20
Head Loss at 20 GPM psi	8.5	8.5
Operating Pressure psi	150	150
Operating Temperature °F	120	120

Sweep Hand Registers:	5/8" x 1/2"	5/8" x 3/4"
US Gallons	10	10
Cubic Feet	1	1
Cubic Meters (Canada)	1/10	1/10
Cubic Meters (Intl.)	1/100	1/100

Capacity of Register (millions):	5/8" x 1/2"	5/8" x 3/4"
US Gallons	10	10
Cubic Feet	1	1
Cubic Meters (Canada)	1/10	1/10
Cubic Meters (Intl.)	1/10	1/10

Register Type: Permanently sealed direct reading

Materials:	
Main Case	Standard waterworks or optional low lead Bronze
Bottom Plate Options	Waterworks or low-lead Bronze, Cast Iron or Polymer
Bottom Gasket-Liner	Nitrile
Body Bolts	Stainless Steel
Measuring Chamber	Compounded Polymer
Division Plate	Loaded Nylon
Piston	High Impact Polymer
Thrust Bearing Insert	Loaded Nylon
Driving Bar	Loaded Nylon
Strainer	Polypropylene
Register Can	90% Copper Alloy
Register Lens	Tempered Glass
Register Housing and Lid	Polymer or Bronze

Operation. The C700 is an oscillating piston style, positive displacement water meter. The product utilizes a piston that water use rotates in a measuring chamber, each piston revolution being equivalent to a known volume of water. The piston movement is transferred by a magnetic drive to a straight reading sealed register which contains the appropriate reduction gearing.

Compliance to Standards. The C700 fully complies with American Water Works Association Standard C700, latest revision, and is California Department of Weights and Measures approved. C700 low-lead bronze models are NSF-61certified and comply with California Proposition 65.

Installation. The meter must be installed in a clean pipeline, free from any foreign materials. Install the meter with direction of flow as indicated by the arrow cast in the meter case. The meter may be installed in horizontal, vertical or inclined lines.

Application. The meter is for use only with POTABLE COLD WATER up to 120°F (50°C) and



working pressures up to 150 psi. The meter will register between 98.5% and 101.5% at normal and high flows and between 97% and 101% at the AWWA specified low flow. Accuracy tests are made before shipment, so no adjustments need to be made before installation.

Construction. The meter consists of a straight through-flow main case, dual inlet measuring chamber, vertically grooved oscillating piston, high capacity strainer, removable bottom plate, full rubber liner, body bolts with integral washers and a magnetically driven register. The main case is cast in waterworks or low-lead bronze with raised characters designating model, size and direction of flow. Maincase bottom plates are available in a choice of polymer, waterworks or low-lead bronze or, if frost protection is desired, in cast iron. The 2-piece snap-fit measuring chamber is of a top and bottom inlet, side output design and features a unique self-flushing sediment well.

Other features include a removable, contoured division plate, captive drive bar and high torque magnet complete with a nylon bushing. The flow-stream balanced piston has a unique thrust bearing insert and features a Turbulence Seal™ system which passes debris while sustaining the most linear accuracy curve in the industry. Each register is secured to the main case with a tamperproof plug to eliminate tampering.

Register. The register is contained within a 90% copper seamless can which is oven-cured at 150°F for 90 minutes to eliminate condensation. The 5 mm true tempered flat glass lens is secured with an "L" shaped gasket, then roll sealed to produce a permanently sealed design. To assure easy reading, the totalizer wheels are large and color coded. The applicable size, model, registration, part number and date code are printed on the calibrated dial face. Moving clockwise during operation, the extra-thin center sweep hand does not interfere with meter reading, and the 1:1 piston ratio low-flow indicator gives visual indication of plumbing leaks. For accurate meter testing, 100 clear graduations appear at the register's circumference.

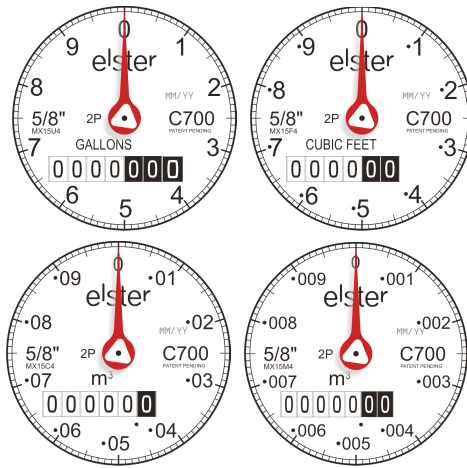

Register Reading Options. C700 meters are available with Absolute Encoder, Generator and Digital register options to provide water usage output to the entire spectrum of meter reading systems, giving flexibility to utilities implementing or upgrading reading technologies. Refer to the following documents for more information:

Absolute Encoder Register	EC-700
Generator Register	RR-C7-810
Digital Register	DR-C700

Magnetic Drive. The magnetic drive design facilitates coupling between the measuring chamber and the external register. The coupling is absolute at all rated flows.

Connections. Meter casing spuds have external straight threads conforming to ANSI B.1.20.1. Bronze coupling nuts and tailpieces are available. Tailpieces have external taper pipe threads conforming to ANSI B.1.20.1. Their lengths and thread sizes are as specified by AWWA Standards.

Maintenance. The measuring chamber assembly can be removed, repaired or replaced. Pretested measuring chamber assemblies are available for exchange or purchase, and spare parts are available from our central warehouse or designated regional locations. Elster AMCO Water staffs and operates a repair facility at its U.S. manufacturing plant in Ocala, Florida.

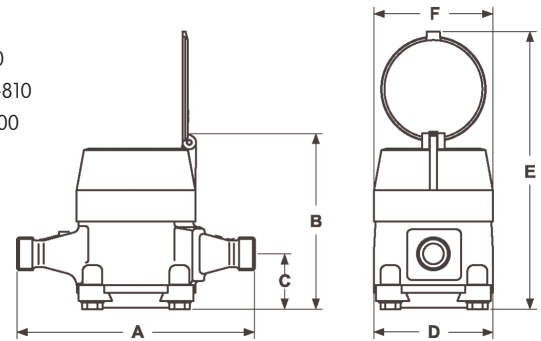

Dimensions and Net Weights

Meter Size	Dimensions (inches)						Weight (lbs.)
	A	B	C	D	E	F	
5/8" x 1/2"	7 1/2	5 1/2	1 1/2	4	8 3/4	3 3/4	3 1/2
5/8" x 3/4"	7 1/2	5 1/2	1 1/2	4	8 3/4	3 3/4	3 1/2

Elster AMCO Water, Inc.
 PO Box 1852
 Ocala, FL 34478-1852
 United States

T +1 800 874 0890
 F +1 352 368 1950

watermeters@us.elster.com
 www.elster.com

© 2007 by Elster. All rights reserved.

The company's policy is one of continuous product improvement and the right is reserved to modify the specifications contained herein without notice. These products have been manufactured with current technology and in accordance with applicable AWWA Standards.