

AquaMaster™ Electronic Water Meter

Sizes: 5/8" - 24"



Materials of Construction

Lining

5/8" - 1"	PPS
1 1/2" - 3"	POM-C
4" - 6"	Chloro-Butyl Rubber
8" - 24"	EPDM

End Connections

5/8"	Brass 3/4" NPSM Threaded
3/4"	Brass 1" NPSM Threaded
1"	Brass 1 1/4" NPSM Threaded
1 1/2" - 24"	Stainless Steel Flange ANSI B16.5 Class 150

Electrodes 316L Stainless Steel

Grounding Rings 304 Stainless Steel

Display Aluminum Alloy with Glass Window

Extended Battery Display Stainless Steel housing, thermoplastic outer cover, polyurethane resin finish

Power Supply

AC Power	85-265V, 47 - 440 Hz, <10 VA
Battery	3.6V Lithium, 1.5 year typical life
Extended Battery Version	5-6 year life

Conductivity >50 µ S/cm

Pressure Limit 150 PSI

The state of the art in water flow measurement, the AquaMaster™ Electronic Water Meter combines outstanding performance, innovative features, user benefits and low cost of ownership to ensure it is your first choice for bulk water, fire service, custody transfer and process management applications. Suitable for use as a utility revenue meter or industrial flow instrument, the AquaMaster™ is your solution to metering problems.

A wide range of configuration options, from power source and display mount to choice of engineering units displayed allow the user to best fit the meter to the application and enjoy the ease of use the meter provides.

Features include:

- Internal battery power options or AC with battery backup
- Very accurate measurement over wide flow range
- Bi-directional flow monitoring
- Daily or weekly tariff functions
- Comprehensive test mode
- Standard pulse output



Application. The meter is suitable for use in applications with potable cold water; water containing debris including ground, well, river and irrigation water, plant maintenance and process applications; as well as treated effluent.

Operation. AquaMaster™ is an electromagnetic water meter operating via Faraday's principle of magnetic induction. A conductive fluid, water, moving through the sensors' magnetic field induces an electrical voltage proportional to the rate of flow of the fluid. The meter measures the voltage between the stainless steel electrodes in the sensor tube and calculates the flow rate. Total volume is inferred from the known cross section of the flow tube.

Compliance to Standards. AquaMaster™ is designed, manufactured and calibrated to internationally recognized standards: ISO 9001, NAMAS, NIST, NATA. FM approval available for Fire Service Meters (see AMCO spec AM-FSM-TS).

The Next Generation Commercial Water Flow Meter

AquaMaster™, available in sizes 5/8" to 24" (15 to 600 mm), is the total solution for flow measurement in the water industry. Outstanding performance, innovative features and user benefits, coupled with low cost of ownership ensures that AquaMaster™ is the first choice for bulk revenue, fire service, custody transfer and production metering.

AquaMaster™ has been designed specifically for the water industry in response to its strin-

gent demands for enhanced metering capability; enabling ever more efficient and cost effective operation and compliance with increasing legal requirements.

In addition to high measurement performance the AquaMaster offers reading of totalizers via the industry standard inductive pad reader or radio frequency automatic meter reading. This feature allows easy access to billing information without the need to physically access the meter.

No External Power Required for Remote Locations

- No external power supply (2 internal batteries)
- 3-year battery life (28 months on 14" meters or larger)
- Site-replaceable batteries
- Unique battery management system gives a battery replacement window in excess of 1 year, with no flat-battery interruption to measurement.

AquaMaster™ is the ideal solution for locations where there is no external power. Through new design technology two user-replaceable internal batteries provide a 3-year battery life, thus eliminating the high cost of providing a power supply to the meter.

Typical Applications

- Bulk revenue
- Custody transfer
- Production metering
- Treated effluent



New Performance Standards

Calibration Characteristics for AquaMaster

The broadest flow range, optimum accuracy and long-term stable calibration means that AquaMaster sets new performance standards in the water industry.

Using the 4" AquaMaster as an example, the charts below illustrate AquaMaster's performance versus new mechanical meters. Compared to AWWA 701 Class II Turbine

Meters, AquaMaster measures significantly lower flows while more accurately measuring the entire turbine flow range.

AquaMaster's high accuracy over a broad flow range also offers a revenue advantage over AWWA C702 Compound Meters. As illustrated for the 4" size, in addition to great accuracy at low flows and $\pm 1\%$ (battery) or $\pm 1\%$ (AC) for normal and high flows, AquaMaster avoids the accuracy loss that occurs at crossover in Compound Meters.

The clear bore of the AquaMaster eliminates the possibility of damage by particulate matter and the absence of moving and wearing components ensures that this unique level of performance is maintained long term.

The design of the AquaMaster sensor conditions the flow profile in the measuring section so that distortions in the flow profile, either upstream or downstream, are flattened, resulting in excellent in situ meter performance, even with poor hydraulic installation conditions.

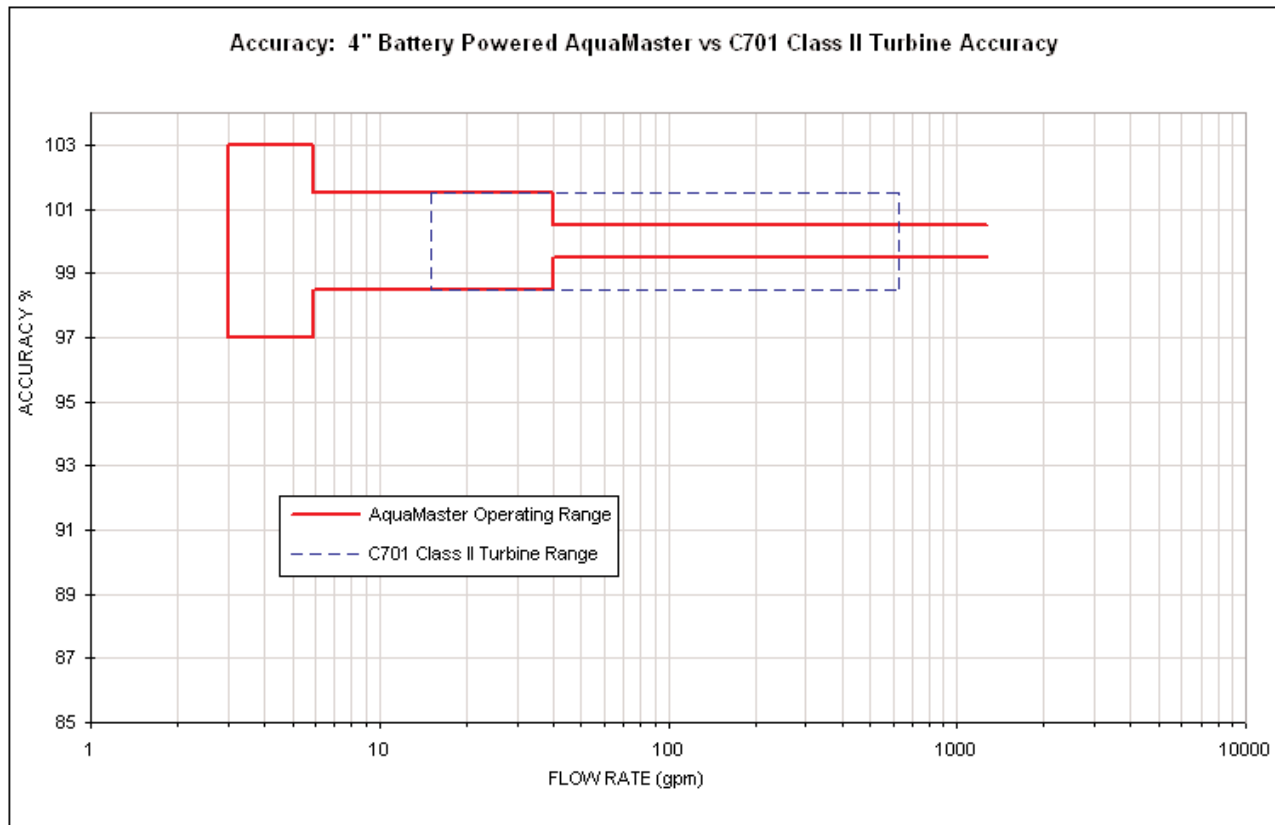

Accuracy: 4" Battery Powered AquaMaster vs C702 Compound Meter

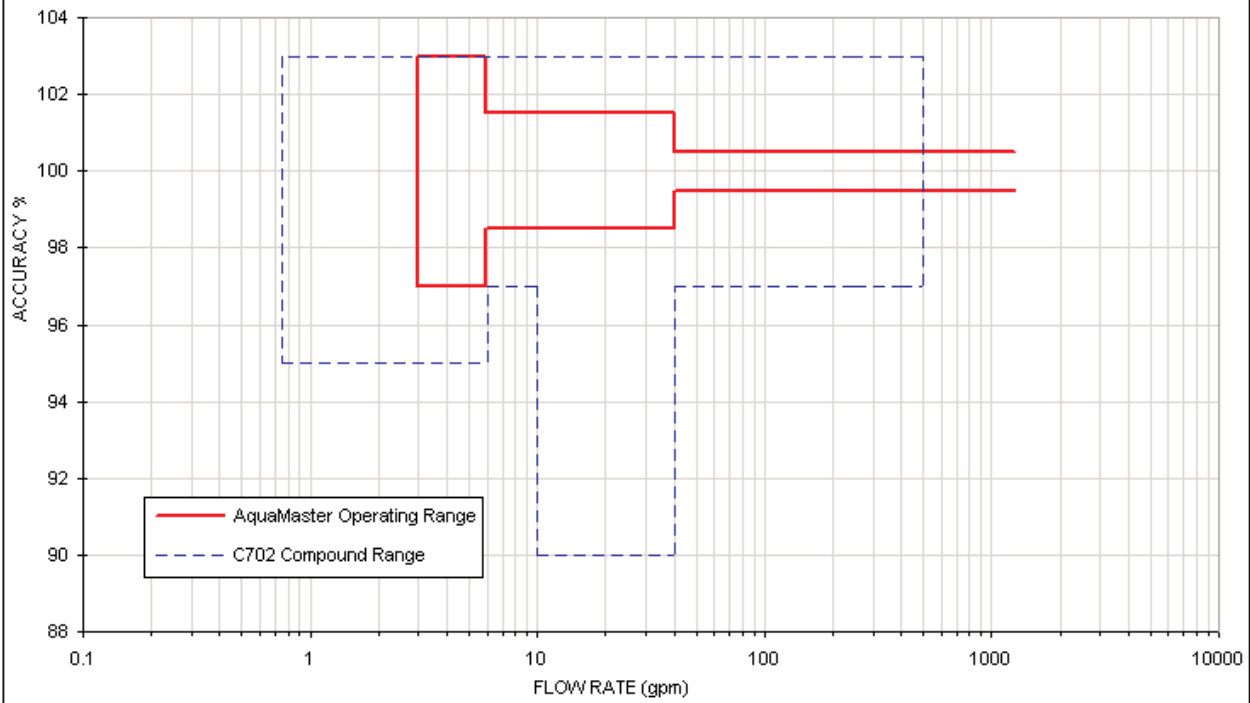

Accuracy: 4" AC Powered/Battery Backup AquaMaster vs C701 Class II Turbine

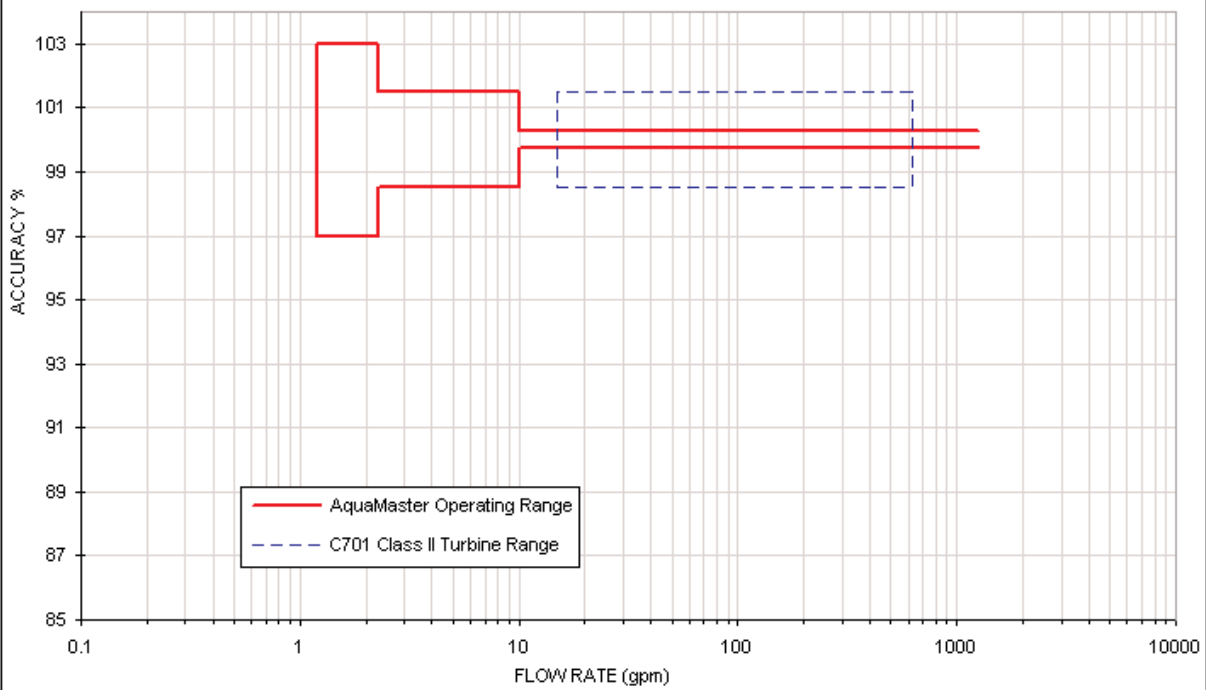

Accuracy: 4" Battery Powered AquaMaster vs C702 Compound Meter

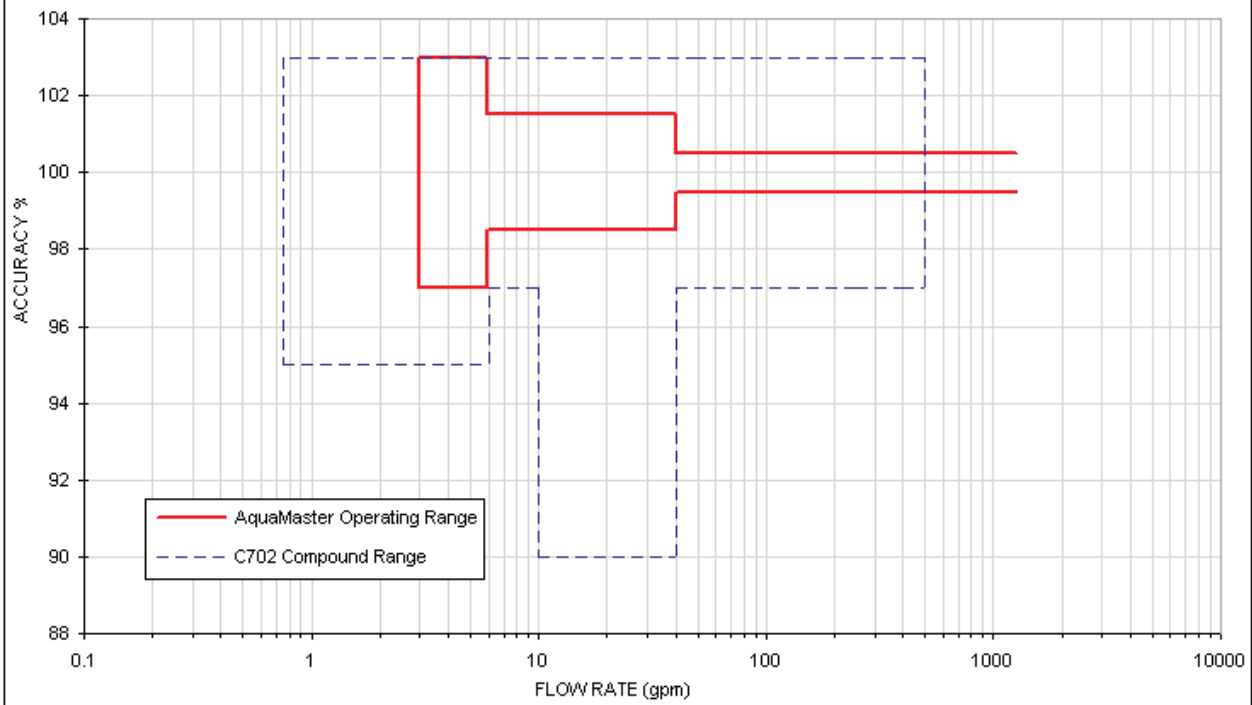

Electronic Display Unit

- Comprehensive display
- Submersible for use in flooded pits rated IP68 (NEMA 6)
- Resettable or secure totals
- 1/5" high displays for totals
(exceeding AWWA register digit requirements)
- Total security:
2 user security levels
Anti-tamper seals and switch
- 3 outputs (pulses and alarm)

The AquaMaster™ Electronic Display Unit provides the most comprehensive range of flow data and information currently available to the water industry. If all the data is not required, the unit can be configured so that only the required values are displayed, thus ensuring simple reading with no superfluous data. Likewise, the display is available for top or side viewing, depending on the location of the meter, for easy reading in all locations.

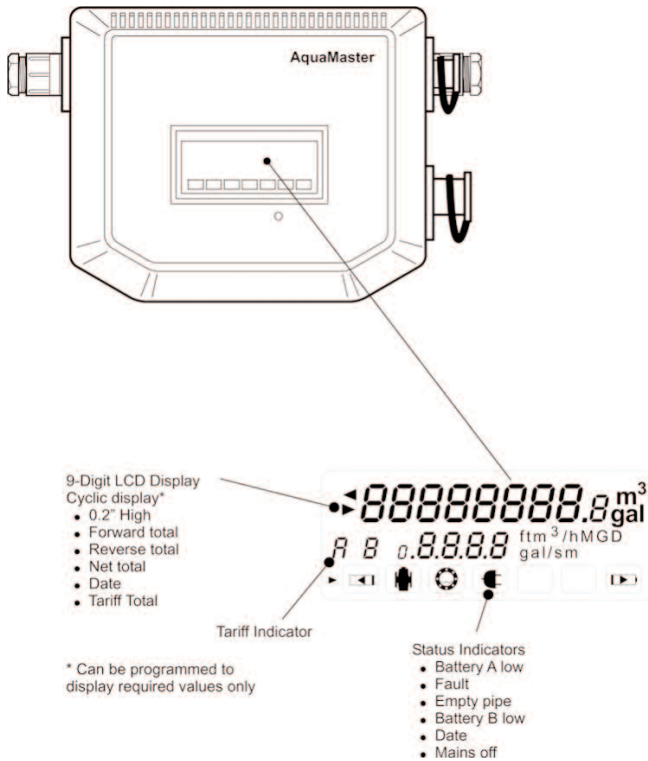

Standard Tariff Setting

AquaMaster incorporates a multiple tariff feature where the accumulated flow volume is routed to one of two 8-digit signed tariffs; tariff A and tariff B, depending on time and date. It is fully programmable by the user for time of day, day of week or date during the year. These user-defined times/dates can be combined in a variety of modes as illustrated in the tables below.

Mode	Tariff A	Tariff B
1	Day time during weekend	Night time at weekend + day and night during week
2	Day time during week	Night time during week + day and night during weekend
3	All day times	All night times
4	Night time during weekend	Day time during weekend + day and night during week
5	Day and night during weekend	Day and night during week
6	Day time during weekend + night time during weekend	Night time during week + day time during weekend
7	All day times + night time during weekend	Night time during week

Mode	Tariff A	Tariff B
1	Day time during summer	Night time during summer + day and night during winter
2	Day time during winter	Night time during winter + day and night during summer
3	All day times	All night times
4	Night time during summer	Day time during summer + day and night during winter
5	Day and night during summer	Day and night during winter
6	Day time during winter + night time during summer	Night time during winter + day time during summer
7	All day times + night time during summer	Night time during winter

Easy, Low Cost Installation

No matter what the location or installation requirements, AquaMaster™ provides a cost-effective solution.

Both the sensor and the Electronic Display Unit are fully submersible, enabling installation in flooded meters vaults.

In addition, the sensor is buriable, thus eliminating the expense of a vault. Installation merely involves excavating to the pipeline, fitting the sensor and back filling the hole, to ensure very fast, low cost installation. The associated Electronic Display Unit is then located in the most convenient position for the user.

For new installations, the elimination of ancillary items (such as strainers) reduce material and installation cost. AquaMaster's compact size allows easy replacement of compound or turbine with the addition of spool pieces.

These factors, together with the innovative 'Fit and Flow™' system, ensure foolproof installation with total user confidence.

Fit and Flow™

- No need to match sensor and Electronic Display Unit
- Fast, reliable installation
- Foolproof, no errors
- Sensor stores all calibration factors, site settings, serial numbers, etc.
- Volume totalizer and tariff values backed-up in sensor for total security
- Multiple, programmable password levels stored for measurement security

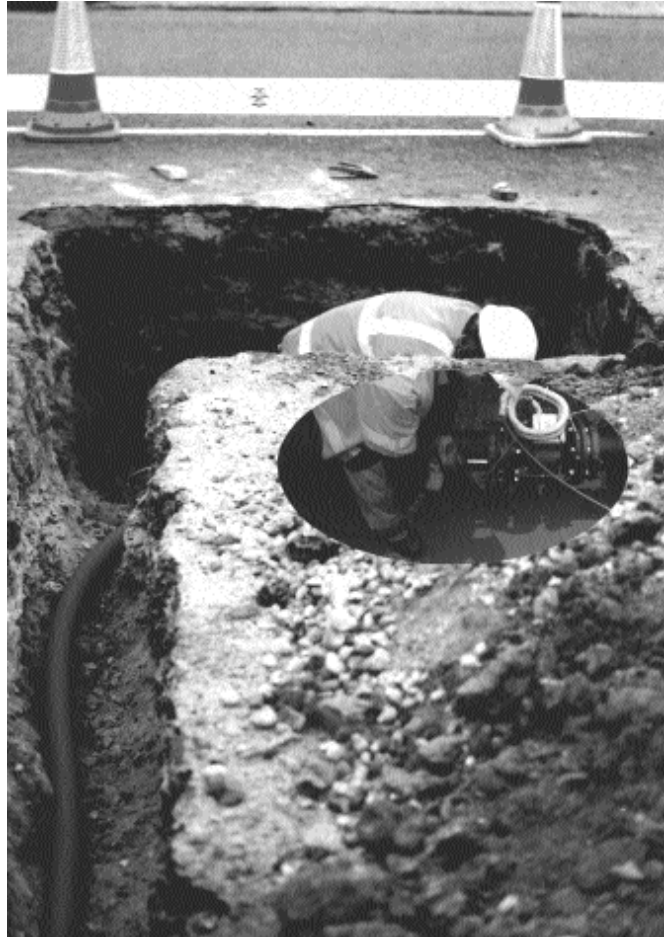

Underground Installation of AquaMaster™

General Specification

AquaMaster - Operating Parameters

	Maximum Flow (gpm) AC: 99.75%-100.25% Bat: 99.5%-100.5%	Continuous Duty Flow (gpm) AC: 99.75%-100.25% Bat: 99.5%-100.5%	Accuracy AC Powered			Accuracy Battery Powered			Head Loss at Continuous Flow (psi)
			Low Flow (gpm) 97%-103%	Low Flow (gpm) 98.5%-101.5%	Normal Flow (gpm) 99.75%-100.25%	Low Flow (gpm) 97%-103%	Low Flow (gpm) 98.5%-101.5%	Normal Flow 99.5%-100.5%	
5/8"	22	18	0.03	0.06	0.33	0.08	0.15	1.0	8.2
3/4"	35	28	0.05	0.09	0.55	0.12	0.23	1.7	7.1
1"	55	44	0.08	0.15	0.77	0.19	0.37	2.2	8.9
1 1/2"	136	110	0.19	0.37	6.60	0.46	0.92	6.6	7.1
2"	220	176	0.3	0.60	6.60	0.74	1.47	10.0	6.8
3"	756	440	0.8	1.50	8.80	1.84	3.67	26	7.0
4"	1,268	700	1.2	2.30	10	3.0	5.9	40	7.1
6"	2,838	1,760	3	6	30	7.5	15	101	8.9
8"	3,658	2,770	4.5	9	60	11.5	23	167	5.5
10"	5,855	4,400	7.5	15	90	18.5	37	264	6.9
12"	8,806	7,040	11.5	23	130	29.5	59	396	7.0
14"	8,806	7,040	23.5	47	352	73.5	147	528	3.5
16"	13,759	11,000	36.5	73	440	91.5	183	660	6.8
18"	19,263	15,400	51.5	103	570	128.5	257	859	8.3
20"	22,014	17,600	58.5	117	660	183.5	367	991	8.7
24"	34,673	27,700	92.5	185	1100	231.0	462	1651	5.3

AquaMaster Operating Parameters Compared to AWWA Class II Turbine Meters (C701)

	Maximum Flow		Continuous Duty Flow		Low Flow		Normal Flow	Head Loss at C701 SMOC	
	AquaMaster (gpm) AC: 99.75%-100.25% Bat: 99.5%-100.5%	C701-88 (gpm) 98.5% -101.5%	AquaMaster (gpm) AC: 99.75%-100.25% Bat: 99.5%-100.5%	C701-88 (gpm) 98.5%-101.5%	AquaMaster AC (gpm) 98.5%-101.5%	AquaMaster-Battery (gpm) 98.5%-101.5%	C701-88 (gpm) 98.5%-101.5%	AquaMaster (psi)	C701-88 (psi)
2"	220	160	176	100	0.6	1.47	4	5.63	7
3"	756	350	440	240	1.5	3.67	8	4.45	7
4"	1268	630	700	420	2.3	5.9	15	5.74	7
6"	2838	1400	1760	920	6	15	30	5.62	7
8"	3658	2400	2770	1600	9	23	50	4.11	7
10"	5855	3800	4400	2500	15	37	75	5.12	7
12"	8806	5000	7040	3300	23	59	120	3.54	7

AquaMaster Operating Parameters Compared to AWWA Compound Meters (C702) Part 1

	Maximum Flow		Continuous Duty Flow		Normal Flow
	AquaMaster (gpm) AC: 99.75% - 100.25% Bat: 99.5% - 100.5%	C702-92 (gpm) 97% -103%	AquaMaster (gpm) AC: 99.75%-100.25% Bat: 99.5% - 100.5%	C702-92 (gpm) 97% -103%	C702-92 (gpm) 97% - 103%
2"	220	160	176	80	2
3"	756	320	440	160	4
4"	1268	500	700	250	6
6"	2838	1000	1760	500	10
8"	3658	1600	2770	800	16
10"	5855	2300	4400	1150	32

AquaMaster Operating Parameters Compared to AWWA Compound Meters (C702) Part 2

	Low Flow				Head Loss at C702 SMOC		
	AquaMaster - AC (gpm)		AquaMaster - Battery (gpm)		C702-92 (gpm) 95% - 101%	AquaMaster (psi)	C702-92 (psi)
	97% - 103%	98.5% - 101.5%	97% - 103%	98.5% - 101.5%			
2"	0.3	0.6	0.7	1.47	0.25	5.63	20
3"	0.8	1.5	1.8	3.67	0.5	3.72	20
4"	1.2	2.3	3.0	5.9	0.75	3.62	20
6"	3	6	7.5	15	1.5	2.87	20
8"	4.5	9	11.5	23	2	1.83	20
10"	7.5	15	18.5	37	4	1.88	20

Wetted Materials

Screw End Meters

Brass

Flanged meters

Stainless Steel

Electrodes

Stainless Steel 316L

Lining

Suitable for potable water

Pressure Limitations

As flange rating

Conductivity

>50µS/cm

End Connections

Thread end connections

5/8" meter - 3/4" NPSM

3/4" meter - 1" NPSM

1" meter - 1 1/4" NPSM

1 ft" to 12" (40 to 300mm) flanged

ANSI B16.5 1.5 Class 150

BS4504/ISO 7005 - PN16, PN10

AS 2129 Tables C, D and E

AS 4087/14, AS4087/16

JIS to BS2210, 5k, 10k and 30k

BS10 Tables D and E

14" to 24" (350 to 600mm) flanged

ANSI B16.5 1.5 Class 150

BS4504/ISO 7005 - PN10, PN16

AS 2129 Tables C, D and E

AWWA C207 Class B and D

AS 4087/14, AS4087/16

Electronic Display Unit

Mounting

Integral with sensor

or

Remote up to 650 ft (200m)

Housing

IP68 (NEMA 6P) Aluminum Alloy with Glass Window

Electrical Connections

20/16mm plastic glands, 20mm armored, or accepts 1/2 in.

NPT threaded or military style plug & socket

Sensor Cable

Elster AMCO Water cable supplied as standard

Special cable available on application

SWA cable available on application

Power Supply

Battery life @ 32 to 122°F (0 to 50°C)

1 battery - typically 1.2 years

2 batteries - typically 3 years (28 months for 14" meters or larger)

Type	Voltage Range (V) Absolute Rating	Frequency (Hz)	VA
AC	85 to 265	47 to 440	<10
Battery	3.6 (Lithium)	-	-

Temperature Ranges

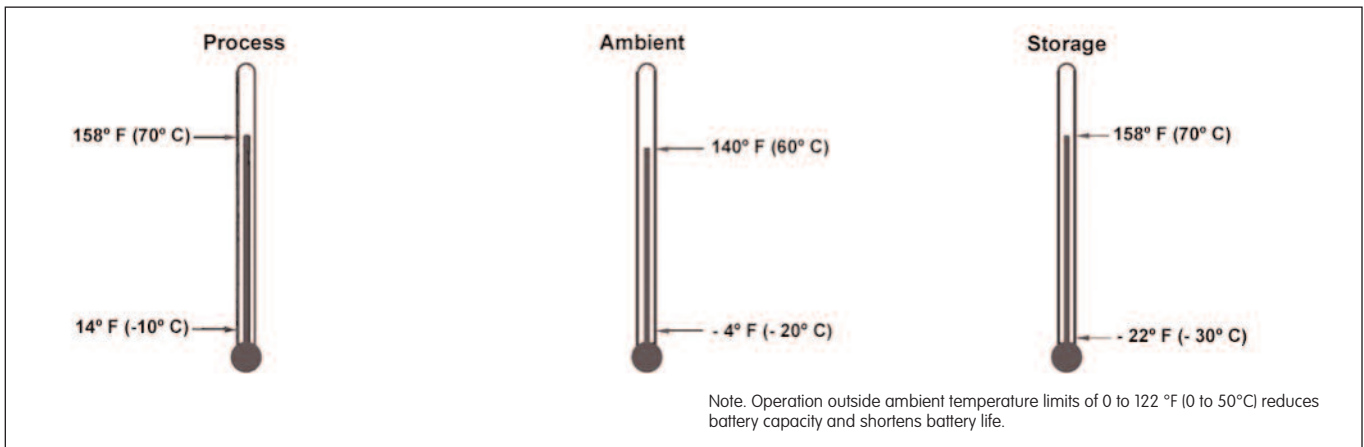

...Electronic Display Unit

Pulse and Alarm Outputs

Three bi-directional solid state switches with common isolation $\pm 35V$ DC 50mA.

Output 1	Forward only, or forward plus reverse pulses
Output 2	Reverse pulses, or direction indicator
Pulse output	50Hz maximum, 50% nominal duty cycle
Output 3	Alarm indicates any problems with the measurement or unit power

Encoder Interface

Function

Remote reading of totalizer and ID.

Protocol

Elster AMCO Water Metering absolute encoder

Connections

2-wire for inductive reading pads (max. cable length 262 ft.)

3-wire for AMR

Compatible readers

T450

Logicon Versaprobe

Iron ERTs, Hexagram MTUs

Compatible inductive pads

Elster AMCO Water Metering

Serial Data Communications

Local Port RS232 compatible via Elster AMCO Water WMS lead (Option)

Remote Port (Option) RS232 with RI, RTS and CTS (Not available with handshaking encoder output option)

Response Time (Programmable)

Minimum

1s (AC powered)
15s (battery powered)

Languages

English
French
Spanish
Languages can be changed via Windows download program (contact Elster AMCO Water)

Mounting

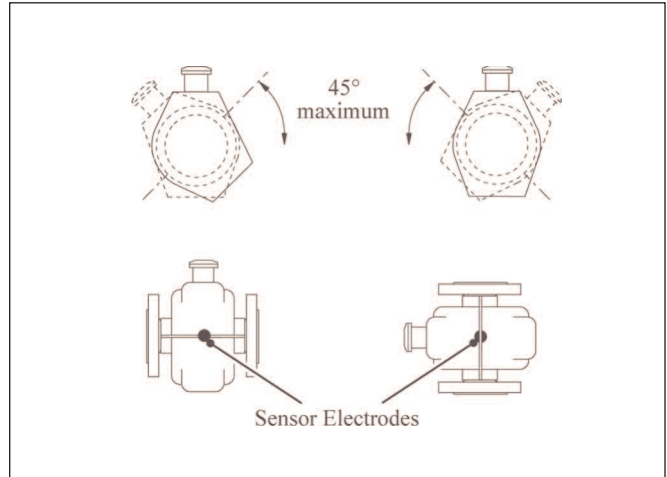

Pipe Conditions

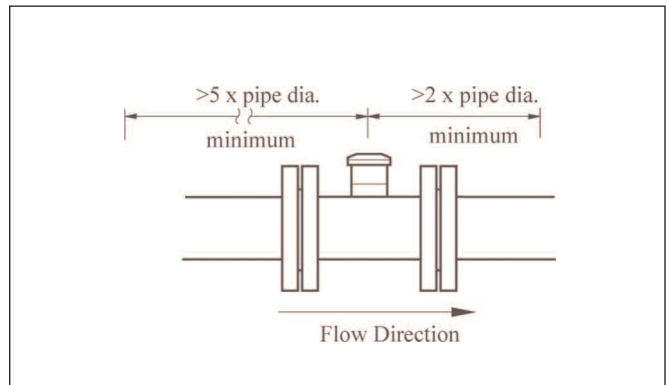

...General Specification

Default Settings Table

Configuration Parameter	Default North America
Pulse Factor	1
Pulse Units	Ugal
Totalizer Units	Ugal
Full Scale Flow	Iso 4064 Qn
Flow Units	MUGD
Velocity Units	ft/s
Date Format from Country Code	MMDDYY
Flow Response Time (s)	3
Display Flow Rate	Yes
Display Forward Total	Yes
Display Reverse Total	Yes
Display Net Total	No
Display Date	No
Display Velocity	No
Output Option Pulse Forward	Pulses Forward
Output Option Pulse Reverse	Pulses Reverse
Profile Factor	1
Probe Insertion Factor	1

Sensor Specification (nominal dimensions)

5/8" to 1" (15 to 25mm) - Screw Ends

Meter Size		Dimensions in. (mm)		Connection	Approx. Weight	
in.	mm	A			lb	kg
5/8	16	4.7 (119)		G 3/4 in. B or 3/4 in. NPSM	5	2.5
3/4	20	5 (127)		G 1 in. B or 1 in. NPSM	5	2.5
1	25	5 (127)		G 1 1/4 in. B or 1 1/4 in. NPSM	5	2.5

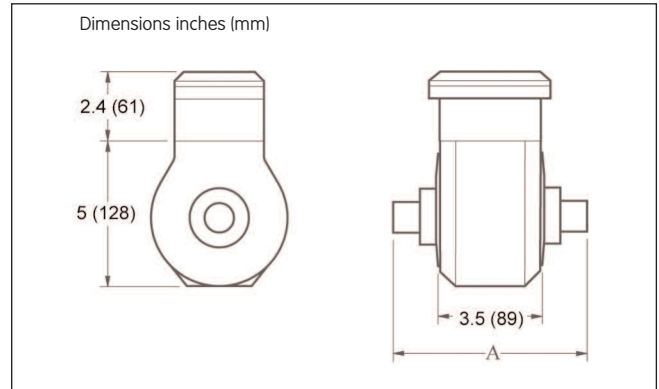

1 1/2" to 12" (40 to 300 mm) - Flanged

Meter Size		Dimensions in. (mm)		Approx. Weight	
in.	mm	A	B	lb	kg
1 1/2	40	7 (176)	7.9 (200)	20	9
2	50	7 (176)	7.9 (200)	23	10
3	80	8.6 (219)	7.9 (200)	40	18
4	100	9.1 (230.5)	9.8 (250)	54	24
6	150	11.1 (281)	11.8 (300)	84	38
8	200	15.8 (402)	13.8 (350)	81	37
10	250	17.3 (440)	17.7 (450)	132	60
12	300	18.9 (480)	19.7 (500)	154	70

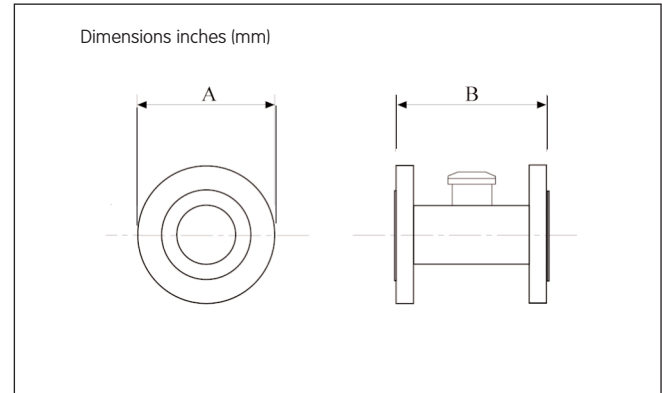

14" to 24" (350 to 600 mm) - Flanged

Meter Size		Dimensions in. (mm)			Approx. Weight	
in.	mm	A	B	C	lb	kg
14	350	20.2 (513)	20.5 (520)	21.7 (550)	220	100
16	400	22.4 (570)	22.7 (576)	23.6 (600)	253	115
18	450	24.9 (632)	24.7 (627)	27.5 (698)	352	160
20	500	27.0 (686)	26.7 (679)	30.2 (768)	455	217
24	600	30.4 (772)	30.3 (770)	36.1 (918)	693	315

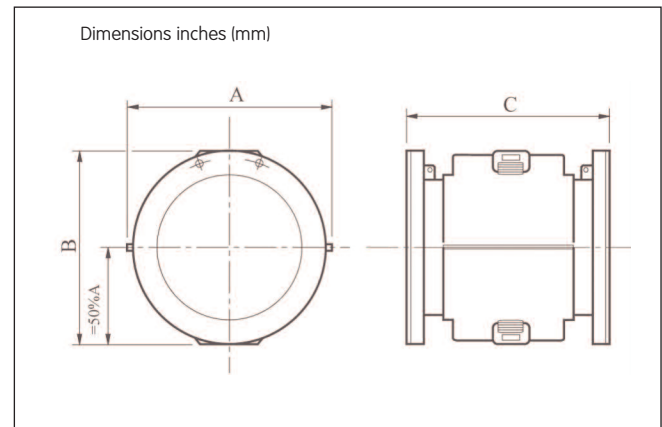

Overall Dimensions

Terminal Box - Sensor Mounted

Dimensions inches (mm)

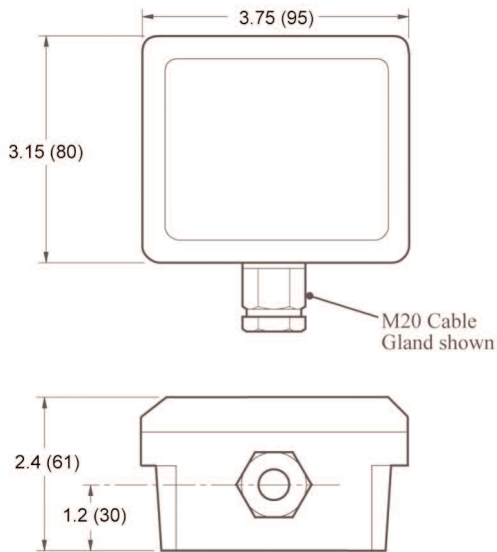

IP68/NEMA6P Metal Electronic Display Unit

Dimension inches (mm)

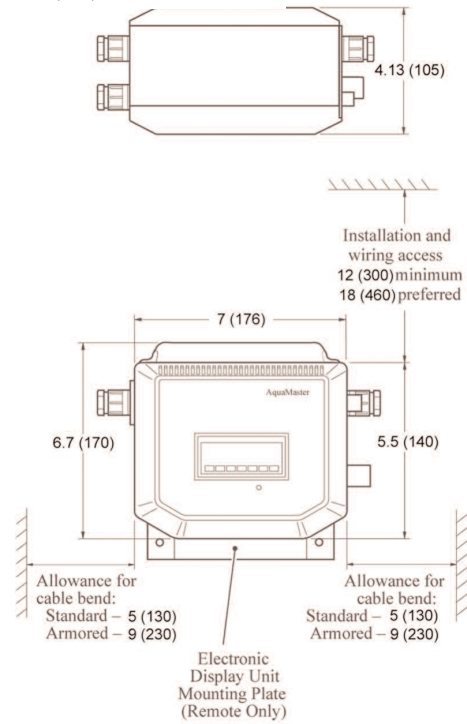

Electrical Connections

Note. For integral mounting, the Electronic Display Unit is supplied mounted on top of the terminal box.

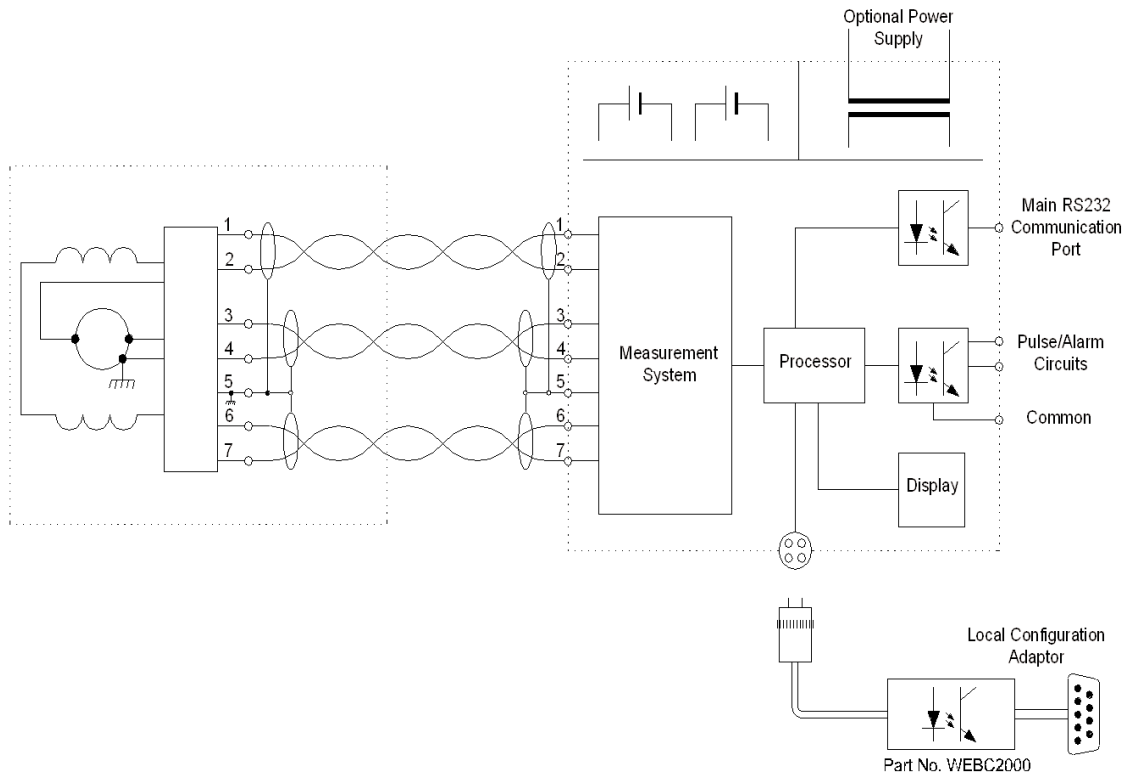

Elster AMCO Water, Inc.
PO Box 1852
Ocala, FL 34478-1852
United States

T +1 800 874 0890
F +1 352 368 1950

watermeters@us.elster.com
www.elster.com

© 2007 by Elster. All rights reserved.

The company's policy is one of continuous product improvement and the right is reserved to modify the specifications contained herein without notice. These products have been manufactured with current technology and in accordance with applicable AWWA Standards.

AM-TS/06-07